

G - Caratteristiche tecniche

2 - Ingombro

Schema generale

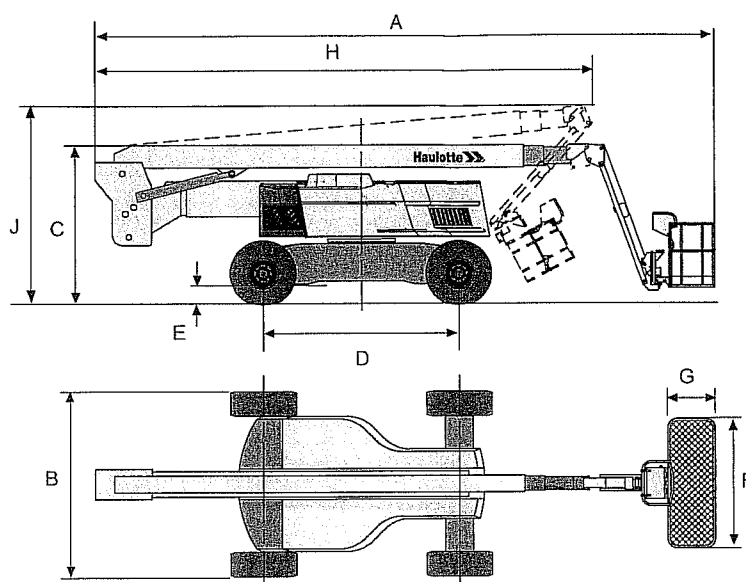

Caratteristiche d'ingombro HA32PX (HA100JRT) - HA41PX (HA130JRT)

Riferimento	HA32PX (HA100JRT)		HA41PX (HA130JRT)	
	Mètre	Feet inch	Mètre	Feet inch
A	11,16	36-7	12,60	41-4
B	2,53	8-3	2,53	8-3
C	2,70	8-10	2,99	9-9
D	3,50	11-5	3,50	11-5
E	0,29	0-11	0,38	1-3
F x G	2,44 x 0,80	8-0 x 2-7	2,44 x 0,80	8-0 x 2-7
H	8,90	29-2	12,30	40-4
J	3,30	10-9	3,70	12-1

G - Caratteristiche tecniche

3.2 - MACCHINA HA41PX (HA130JRT)

Zona di lavoro

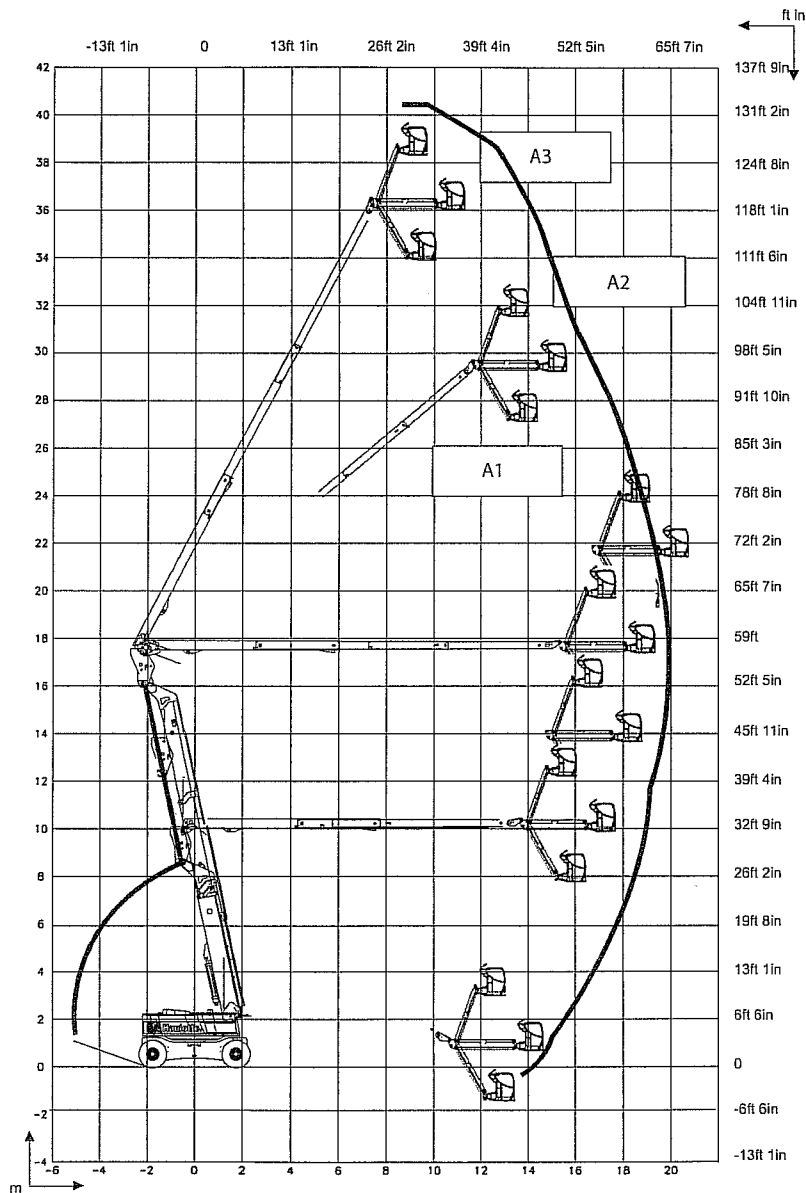

A
B
C
D
E
F
G
H
I